

280™ Heavy Duty Cartridge Dual Seal

SEAL INSTALLATION

Preparation

Determine if the pump is in good condition.

A. Check the shaft or sleeve.

1. Remove all burrs and sharp corners, especially in areas where the O-Ring has to slide. Cover threads and keyway slots with a thin tape to prevent cutting the O-Ring. The distance from the stuffing box face to the center of the O-Ring groove is approximately: 1.50" (38,1 mm) for 1.000" through 2.500" (25 mm through 60 mm); 2.00" (50,8 mm) for 2.625" through 4.750" (65 mm through 120 mm); 3.00" (76,2 mm) for 5.000" through 8.000" (130 mm through 200 mm); 4.00" (101,6 mm) for 8.250" through 12.000" (210 mm through 300 mm).
2. The shaft finish should be 32 microinches RA (0,8 microns) maximum. It should feel smooth if you run your fingernail down it axially.
3. **Make sure the shaft or sleeve diameter is within +/- .002" (0,05 mm) of nominal.**
4. Use a dial indicator to measure the shaft runout in the area where the seal is to be installed. (**Readings should not exceed .001" (0,03 mm) TIR per inch of shaft diameter.**)
5. Place the dial indicator on the end of the shaft and alternately push and pull the shaft axially to measure end play. End play should not exceed .005" (0,12 mm) TIR.
6. Protect the sleeve O-Ring by lubricating the shaft with a clean silicone based lubricant, as that provided with the seal.

B. Check the stuffing box.

1. The stuffing box face must be a maximum of 125 microinches RA (3,2 microns) for a gasket to seal.
2. Split case pumps will sometimes cause a step (misalignment) to occur on the stuffing box face. This step must be machined flat.

3. Make sure the stuffing box is clean and clear along its entire length.
4. If possible, attach a base dial indicator to the shaft and rotate both the indicator and shaft slowly while reading the runout of the stuffing box face. Misalignment of the stuffing box face relative to the shaft should not exceed .005" (0,12 mm) TIR per inch of shaft diameter.

Installation

1. Check the chemical listing to determine if the O-Rings installed in this seal are compatible with the fluid being sealed.
2. The 1/4 dog point set screws go into the small holes in the sleeve. Do not disengage these screws from the sleeve when positioning the seal. The cup point set screws go through the larger holes in the sleeve. Make sure all screws are engaged in the sleeve but do not protrude into the ID bore. Also, when repositioning or removing the seal, make sure the centering clips and socket head cap screws are engaged.
3. The centering clips have been preset at the factory. If for any reason you loosen or remove the centering clip cap screws, re-tighten each cap screw finger tight (approximately 15 inch-pounds [1,7 Nm] of torque). **Make sure that the lip on the end of the centering clip is inside the gland groove.**
4. **CAUTION:** If the seal is operating at a stuffing box pressure over 300 Psig (20 bar g) or the shaft is case hardened, replace the 316SS cup point set screws with the hardened steel cup point screws supplied with the seal.
5. Slide the seal onto the shaft making sure the 1/4 dog point set screws are engaged through the seal sleeve.
6. Reassemble the pump and make necessary shaft alignments and impeller adjustments. The impeller can be reset at any time, as long as the centering

clips are in place and the seal set screws are loosened while the shaft is being moved.

7. Orient the barrier fluid connections to the location required. The ports are plugged prior to shipping. Remove plugs.
8. Piping connections should not be made prior to tightening the gland bolts.
9. Tighten the gland bolts evenly. **IMPORTANT: The gland bolts must be tightened before tightening the set screws onto the shaft.**
10. **IMPORTANT: All 1/4 dog point set screws must be tightened FIRST.** See figures 1 and 2 below for location of dog point set screws. If rotation of the lock ring is required for tightening set screws, loosen or remove one centering clip. Finger tighten each 1/4 dog point set screw by twisting the short end of the hex key with your finger tips. Then tighten each 1/4 dog point set screw per the recommended tightening torque shown on the chart at the bottom of page 2.
11. Once the 1/4 dog point set screws are tightened, finger tighten each set screw by twisting the short end of the hex key with your finger tips until the point of each set screw touches the shaft. Then tighten each set screw per recommended tightening torque shown on the chart at the bottom of page 2.
12. Remove socket head cap screws and centering clips. Retain for later use.
13. **IMPORTANT: It is important to make sure that the gland is properly centered over the sleeve.** To do this, turn the shaft by hand to make sure the seal turns freely. If you hear metal to metal contact within the seal, it was improperly centered. Replace the centering clips finger tight, loosen gland bolts, tighten clips, re-tighten gland bolts, and then remove clips. If metal to metal contact still exists, check the centering of the stuffing box.

SEAL INSTALLATION

14. Piping connections should not be made until the gland nuts are tightened.
15. The **BARRIER FLUID CONNECTIONS** are 1/4" NPT for 1.00" through 1.50" (25 mm through 38 mm), 3/8" NPT for 1.625" through 2.50" (40 mm through 60 mm), 1/2" NPT for 2.625" through 8.00" (65 mm through 200 mm), and 3/4" NPT for 8.25" through 12.00" (210 mm through 300 mm).
16. This seal is equipped with a pumping device to circulate the barrier fluid. **(The piping connections are dependent on shaft rotation.)**
Direction of shaft rotation is determined when looking at the lock ring end of the seal.

Convection

(when ports are positioned at 12:00)

A. CLOCKWISE shaft rotation

The cool fluid from the bottom of the convection tank enters through the right port.

The hot fluid exits the seal through the left port and goes to the top of the convection tank.

Add fluid, typically 50/50 ethylene glycol and water or Chesterton 610 Synthetic Lubricating Oil, to the convection tank.

B. COUNTER-CLOCKWISE shaft rotation

The cool fluid from the bottom of the convection tank enters through the left port.

The hot fluid exits the seal through the right port and goes to the top of the convection tank.

Add fluid, typically 50/50 ethylene glycol and water or Chesterton 610 Synthetic Lubricating Oil, to the convection tank.

Forced Circulation

(when ports are positioned at 12:00)

A. CLOCKWISE shaft rotation

The cool fluid enters through the right port.

The hot fluid exits through the left port.

B. COUNTER-CLOCKWISE shaft rotation

The cool fluid enters through the left port.

The hot fluid exits through the right port.

Take all necessary precautions and follow normal safety procedures before starting equipment.

SCREW AND BOLT TORQUE

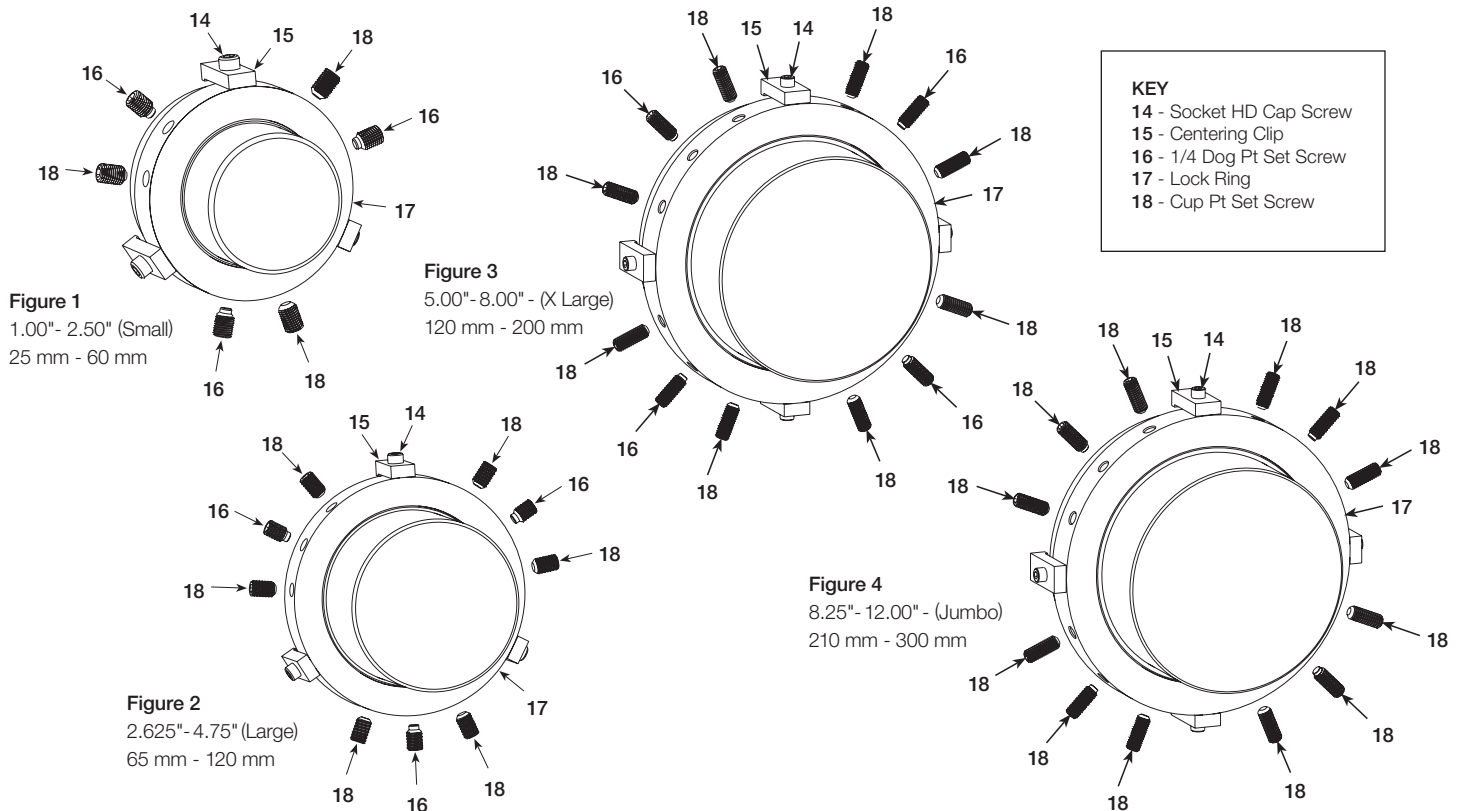

SEAL SIZE	DOG POINT SET SCREWS	CUP POINT SET SCREWS	STUFFING BOX BOLTS
up to 2.50" (60 mm)	50-60 in-lbf (5,7-6,8 Nm)	50-60 in-lbf (5,7-6,8 Nm)	20-30 ft-lbf (27-40 Nm)
up to 4.75" (120 mm)	65-75 in-lbf (7,3-8,3 Nm)	65-75 in-lbf (7,3-8,3 Nm)	25-35 ft-lbf (34-48 Nm)
up to 8.00" (200 mm)	120-135 in-lbf (13,6-15,3 Nm)	120-135 in-lbf (13,6-15,3 Nm)	40-60 ft-lbf (54-81 Nm)
up to 12.00" (300 mm)	None	290-310 in-lbf (32,8-35,0 Nm)	As required

CAUTIONS

These instructions are general in nature. It is assumed that the installer is familiar with seals and certainly with the requirements of their plant for the successful use of mechanical seals. If in doubt, get assistance from someone in the plant who is familiar with seals or delay the installation until a seal representative is available. All necessary auxiliary arrangements

for successful operation (heating, cooling, flushing) as well as safety devices must be employed. These decisions are to be made by the user. The chemical listing is intended as a general reference for this seal only. The decision to use this seal or any other Chesterton seal in a particular service is the customer's responsibility.

PARTS IDENTIFICATION

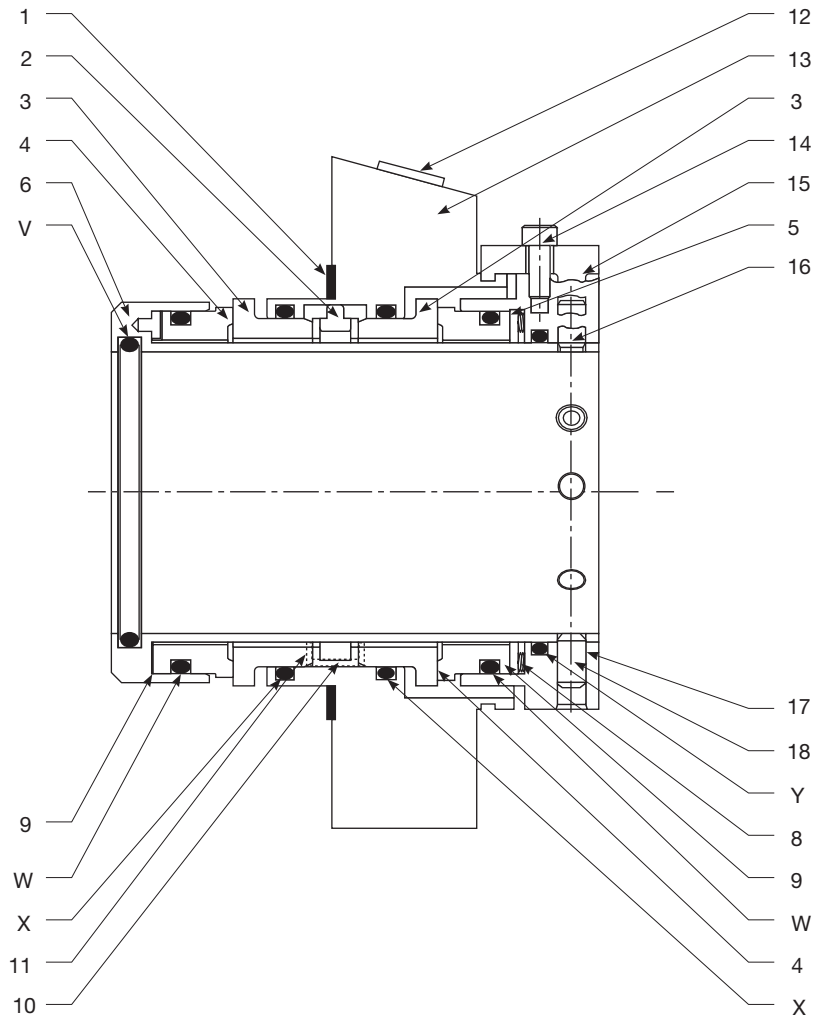

STANDARD MATERIALS*

All Metal Parts:

- 316 SS / EN 1.4401

Springs:

- Alloy C276 / EN 2.4819

O-Rings:

- Fluorocarbon, FEPM or EPR installed

Rotary Face:

- Carbon, Silicon Carbide, Tungsten Carbide

Stationary Face:

- Silicon Carbide, Tungsten Carbide

Speed:

- To 4000 FPM (20 mps).

Pressure:

- To 600 psig (40 bar g) inboard, 250 psig (17 bar g) outboard, up to 4.75" (120 mm) shaft size.
- To 300 psig (20 bar g) inboard, 200 psig (13 bar g) outboard, up to 12.00" (300 mm) shaft size.

Temperature:

- To 300°F (150°C) Ethylene Propylene,
- To 400°F (205°C) Fluorocarbon, FEPM,
- To 500°F (260°C) Perfluoroelastomer.

Minimum Barrier Fluid Pressure:

- 30 psig (2 bar g) minimum barrier fluid pressure is recommended to properly lubricate outboard seal.

*Other materials available upon request.

KEY

- | | |
|-----------------------|----------------------------|
| 1 - Gasket | 13 - Gland |
| 2 - Lug | 14 - Socket Head Cap Screw |
| 3 - Stationary Face | 15 - Centering Clip |
| 4 - Rotary Face | 16 - 1/4 Dog Pt. Set Screw |
| 5 - Follower Assembly | 17 - Lock Ring |
| 6 - Sleeve Assembly | 18 - Set Screw |
| 8 - Spring | V - Shaft O-Ring |
| 9 - Rotary Gasket | W - Rotary O-Ring |
| 10 - Channel | X - Stationary O-Ring |
| 11 - Channel Clip | Y - Lock Ring O-Ring |
| 12 - Port Plug | |

280 STANDARD DIMENSIONAL DATA (INCH)

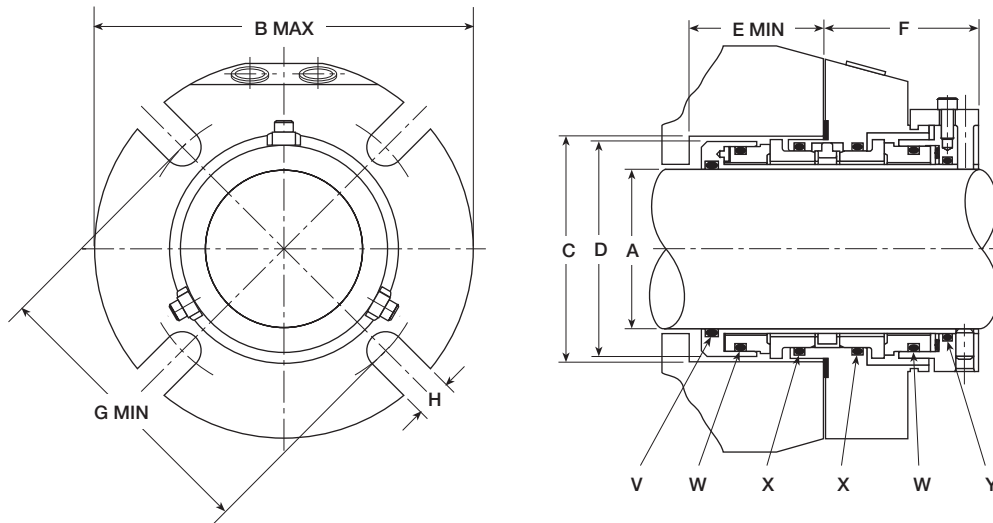

KEY

- | |
|--------------------------------------|
| A - Shaft Size |
| B - Maximum Gland Diameter |
| C - Stuffing Box Inside Diameter |
| D - Seal Diameter in Stuffing Box |
| E - Minimum Stuffing Box Depth |
| F - Outboard Seal Length |
| G - Minimum Bolt Circle by Bolt Size |
| H - Slot Width |
| V - Shaft O-Ring |
| W - Rotary O-Ring |
| X - Stationary O-Ring |
| Y - Lock Ring O-Ring |

ASSEMBLY / DISASSEMBLY

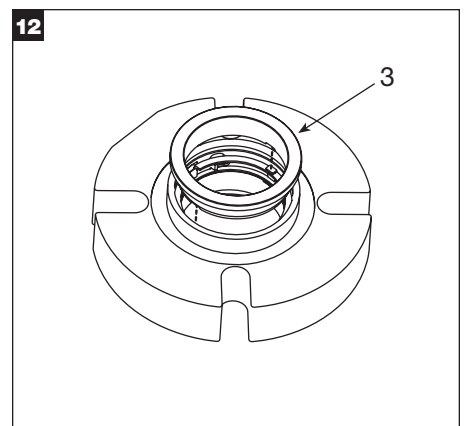
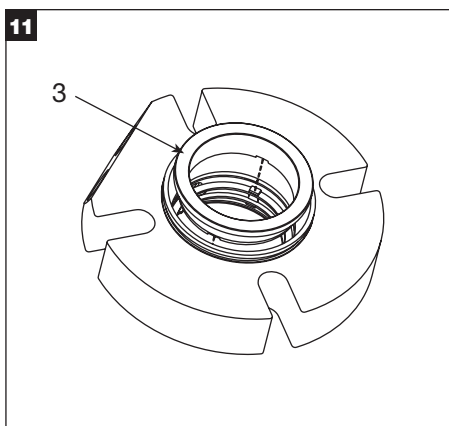
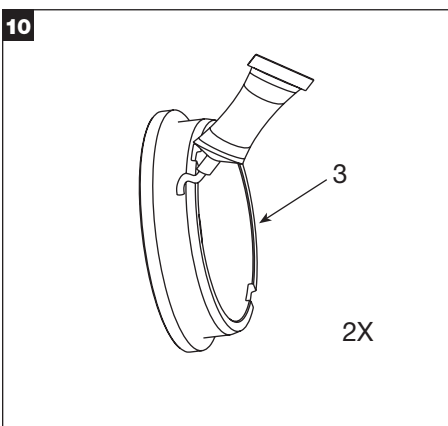
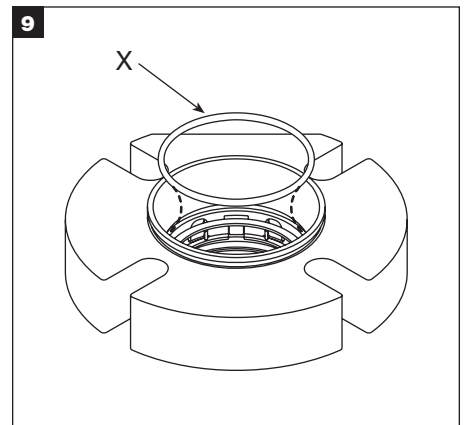
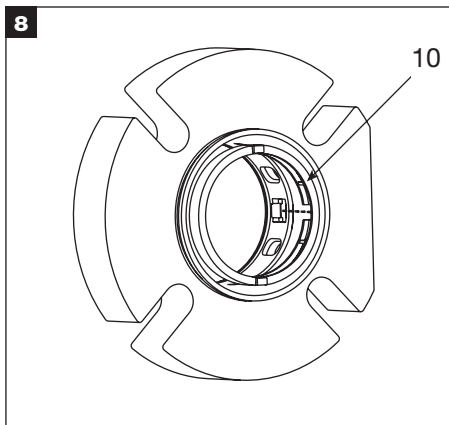
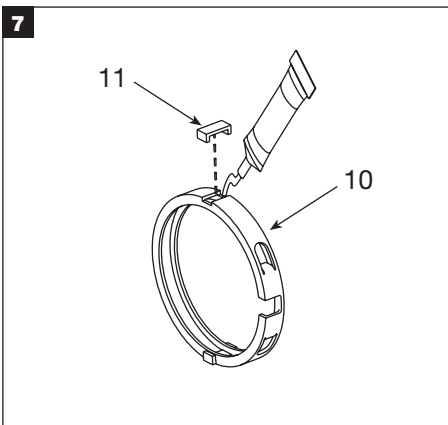
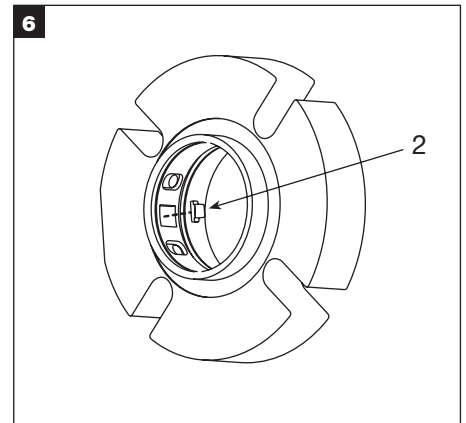
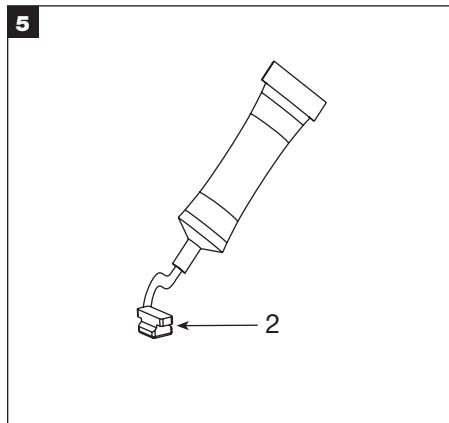
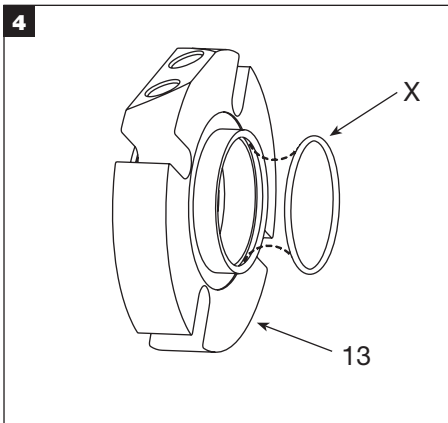
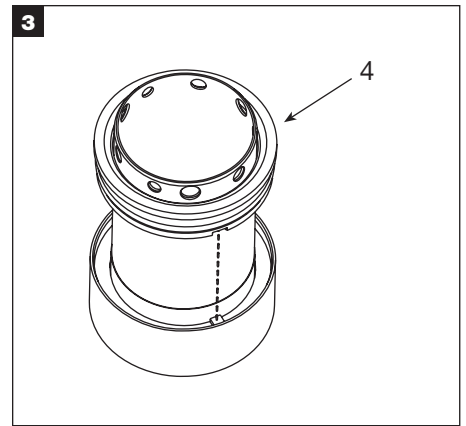
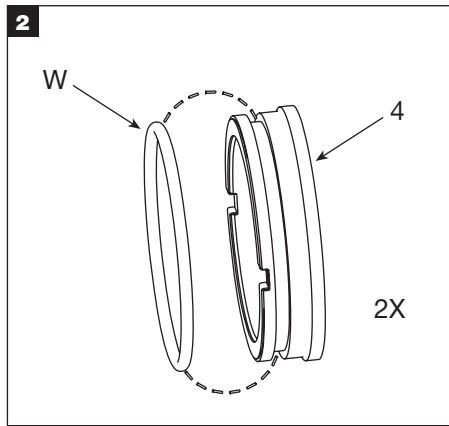
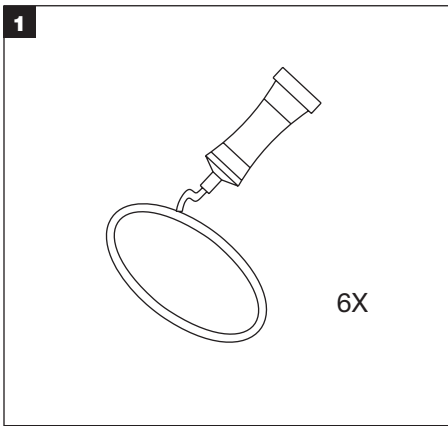

ASSEMBLY / DISASSEMBLY

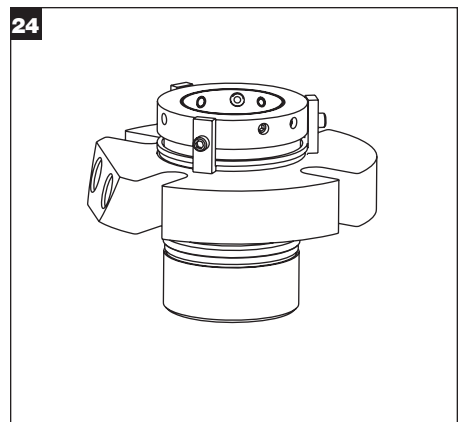
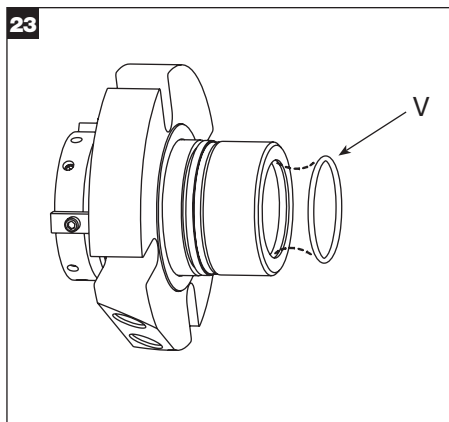
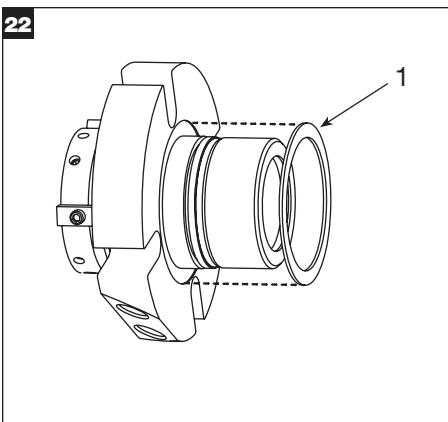
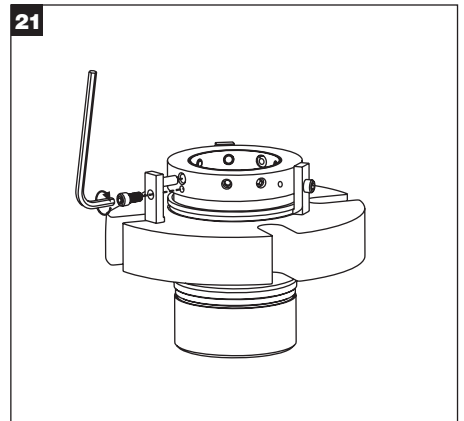
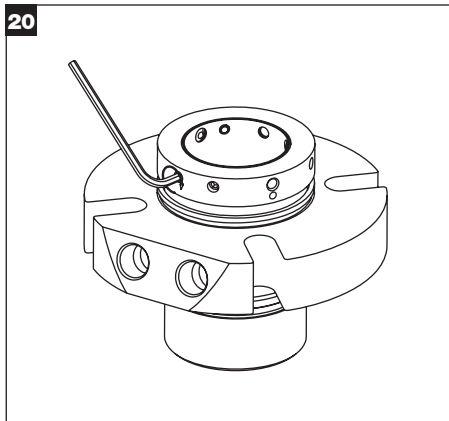
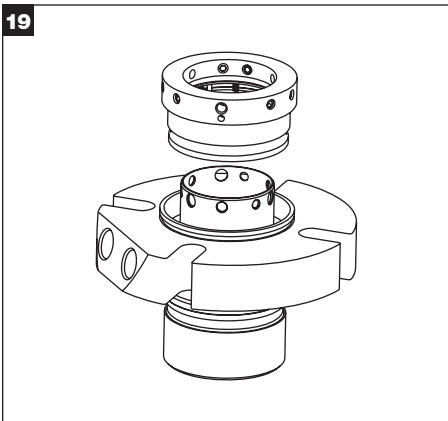
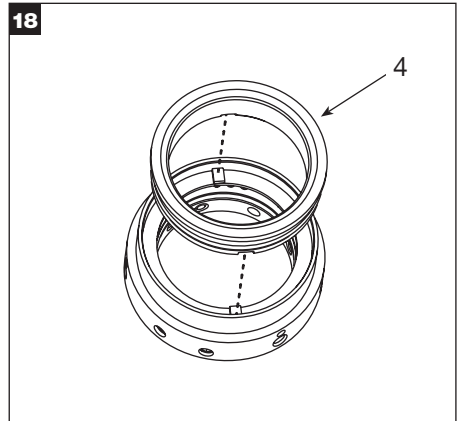
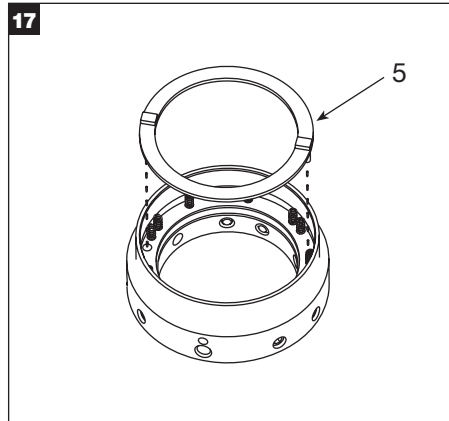
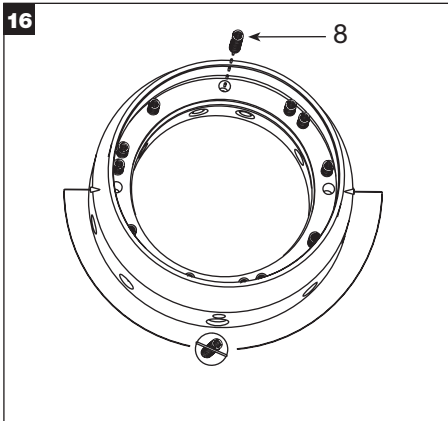
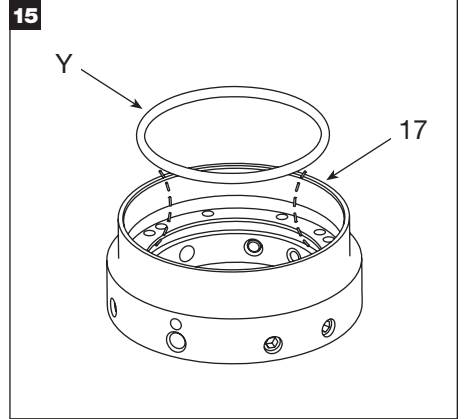
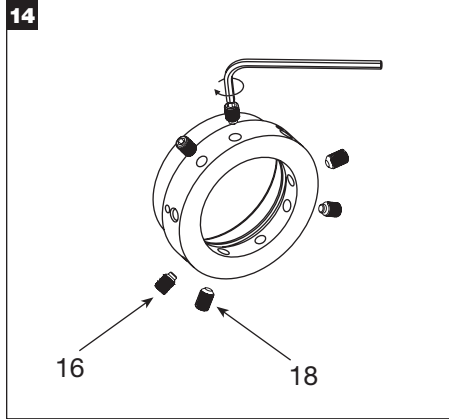
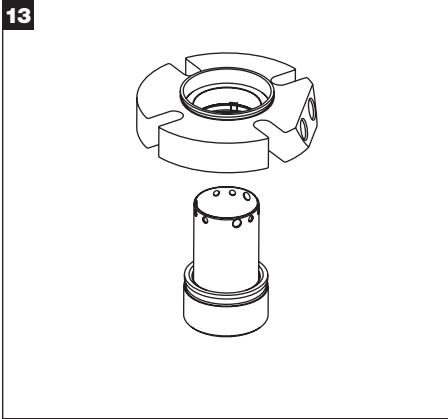

280 STANDARD AND OVERSIZE DIMENSIONAL DATA (INCH)

DASH NO.	SHAFT SIZE	GLAND OD	STUFFING BOX BORE		IB SEAL DIA	SB DEPTH	OB LENGTH	BOLT CIRCLE BY BOLT SIZE					SLOT WIDTH	O-RINGS			
														SHAFT	ROTARY	STATIONERY	LOCK RING
								A	B MAX	C MIN	C MAX	D MAX		E MIN	F MAX	G MIN	
							3/8"	1/2"	5/8"	3/4"	7/8"						
-8	1.000	4.11	1.75	2.01	1.73	1.58	2.13	2.88					0.44	120	126	127	122
-9	1.125	4.11	1.88	2.04	1.86	1.58	2.13	2.88					0.44	122	128	129	124
-10	1.250	4.11	2.00	2.27	1.98	1.58	2.13	3.14					0.44	124	130	131	126
-11	1.375	4.36	2.13	2.33	2.11	1.58	2.13	3.13	3.25				0.57	126	132	133	128
-11OS	1.375	5.40	2.81	3.00	2.80	1.58	2.13	4.00					0.44	126	132	133	128
-12	1.500	4.49	2.25	2.44	2.23	1.58	2.13	3.33	3.45				0.57	128	134	135	130
-13	1.625	4.99	2.38	2.69	2.36	1.58	2.13	3.52	3.65				0.57	130	136	137	132
-14	1.750	5.49	2.50	2.81	2.48	1.58	2.13	3.65	3.77				0.57	132	138	139	134
-14OS	1.750	6.64	3.50	3.75	3.48	1.58	2.13	5.37	5.49				0.57	132	138	139	134
-15	1.875	5.49	2.63	2.94	2.61	1.58	2.13	3.78	3.90				0.57	134	140	141	136
-15OS	1.875	5.99	3.56	3.81	3.54	1.58	2.13	4.88	5.00				0.57	134	140	141	136
-16	2.000	5.49	2.75	3.19	2.73	1.58	2.13	4.03	4.15				0.57	136	142	143	138
-17	2.125	5.99	2.88	3.44	2.85	1.58	2.13	4.28	4.41	4.53			0.69	138	144	145	140
-17OS	2.125	6.99	3.88	4.25	3.87	1.58	2.13			6.00			0.69	138	144	145	140
-18	2.250	5.99	3.00	3.56	2.98	1.58	2.13	4.40	4.53	4.65			0.69	140	146	147	142
-19	2.375	5.99	3.13	3.59	3.11	1.58	2.13	4.46	4.59	4.71			0.69	142	148	149	144
-20	2.500	6.49	3.25	3.81	3.23	1.58	2.13	4.65	4.78	4.90			0.69	144	150	151	146
-20OS	2.500	7.77	4.50	5.25	4.49	1.58	2.13			6.75			0.69	144	150	151	146
-21	2.625	6.45	3.63	3.93	3.60	2.05	2.50		5.02	5.15			0.69	231	235	236	149
-21OS	2.625	6.98	4.55	4.56	4.54	2.05	2.50			6.00			0.69	231	235	236	149
-22	2.750	7.71	3.75	4.44	3.73	2.05	2.50		5.42	5.55			0.69	232	236	237	151
-22OS	2.750	7.89	4.45	4.56	4.44	2.05	2.50				6.38		0.82	232	236	237	151
-23	2.875	7.83	3.88	4.56	3.85	2.05	2.50		5.50	5.62			0.69	233	237	238	151
-24	3.000	7.94	4.00	4.69	3.97	2.05	2.50		5.65	5.77			0.69	234	238	239	152
-24OS	3.000	8.64	4.93	5.17	4.92	2.05	2.50			7.00	7.13	7.25	0.94	234	238	239	152
-25	3.125	7.99	4.13	4.81	4.10	2.05	2.50		5.80	5.92			0.69	235	239	240	152
-26	3.250	8.19	4.25	4.94	4.22	2.05	2.50		5.93	6.05			0.69	236	240	241	153
-27	3.375	8.31	4.38	5.06	4.35	2.05	2.50		6.02	6.14	6.27		0.81	237	241	242	153
-27OS	3.375	8.39	4.95	5.06	4.94	2.05	2.50				6.88		0.82	237	241	242	153
-28	3.500	8.44	4.50	5.19	4.47	2.05	2.50		6.18	6.31	6.43		0.81	238	242	243	154
-29	3.625	8.49	4.63	5.31	4.60	2.05	2.50		6.31	6.44	6.56		0.81	239	243	244	154
-30	3.750	8.72	4.75	5.44	4.72	2.05	2.50		6.38	6.51	6.63		0.81	240	244	245	155
-30OS	3.750	9.76	5.97	6.18	5.94	2.05	2.50			8.25			0.69	240	244	245	155
-31	3.875	8.84	4.88	5.56	4.85	2.05	2.50		6.52	6.64	6.77		0.81	241	246	247	156
-32	4.000	8.96	5.00	5.69	4.97	2.05	2.50		6.66	6.78	6.91		0.81	242	246	247	156
-33	4.125	8.99	5.13	5.81	5.10	2.05	2.50		6.79	6.90	7.03		0.81	243	247	248	157
-33OS	4.125	9.76	5.97	6.06	5.94	2.05	2.50					8.00	0.94	243	247	248	157
-34	4.250	8.99	5.25	5.94	5.22	2.05	2.50		6.91	7.04	7.16		0.81	244	248	249	157
-35	4.375	9.34	5.38	6.06	5.35	2.05	2.50		7.03	7.15	7.28		0.81	245	249	250	157
-36	4.500	9.49	5.50	6.19	5.47	2.05	2.50		7.18	7.30	7.43		0.81	246	250	251	158
-36OS	4.500	12.49	6.78	7.25	6.75	2.05	2.50				10.73		0.89	246	250	251	158
-37	4.625	9.49	5.63	6.31	5.60	2.05	2.50		7.28	7.40	7.53		0.81	247	251	252	158
-38	4.750	10.49	5.75	6.44	5.72	2.05	2.50		7.40	7.53	7.65		0.81	248	252	253	159
-38OS	4.750	11.39	7.22	7.42	7.19	2.05	2.50			9.88	10.00		0.82	248	252	253	159

280 STANDARD DIMENSIONAL DATA (METRIC)

SHAFT SIZE	GLAND OD	STUFFING BOX BORE		IB SEAL DIA	SB DEPTH	OB LENGTH	BOLT CIRCLE BY BOLT SIZE				SLOT WIDTH	O-RINGS				
												SHAFT	ROTARY	STATIONERY	LOCK RING	
							A	B MAX	C MIN	C MAX		D MAX	E MIN	F MAX	G MIN	
							10 mm	12 mm	16 mm	20 mm						
25	104	45	51	44	40	54	74					11	120	126	127	121
28	104	48	52	47	40	54	74					11	122	128	129	123
30	104	50	56	49	40	54	78					11	123	129	130	125
32	104	52	57	51	40	54	80					11	124	130	131	126
33	113	53	58	52	40	54	81	83				14	125	131	132	127
35	111	54	59	53	40	54	80	82				14	126	132	133	128
38	114	60	61	57	40	54	85	87				14	128	134	135	130
40	127	60	68	59	40	54	90	92				13	129	135	136	131
43	127	63	68	62	40	54	91	93				13	131	137	138	133
45	139	65	73	64	40	54	95	97				13	133	139	140	134
48	139	68	73	67	40	54	96	98				13	134	141	142	136
50	139	70	78	69	40	54	100	102				13	136	142	143	137
55	152	75	83	74	40	54	105	107	111			17	139	145	146	140
60	152	80	91	79	40	54	114	116	120			17	142	148	149	143
65	164	92	100	91	52	64		127	131			17	231	235	236	148
70	196	96	113	95	52	64		137	141			17	232	236	237	151
75	202	102	119	101	52	64		143	147			17	234	238	239	5-557
80	203	106	122	105	52	64		147	151			17	236	239	240	153
85	211	111	129	110	52	64		152	156	160		21	237	241	242	153
90	214	116	132	115	52	64		160	164	168		21	239	242	243	154
95	221	121	138	120	52	64		161	165	169		21	240	244	245	155
100	228	127	144	126	52	64		168	172	176		21	242	246	247	5-833
110	237	137	154	136	52	64		178	182	186		21	245	249	250	157
120	266	146	163	145	52	64		187	191	195		21	248	252	253	5-403

280 MIXER DIMENSIONAL DATA (INCH)

DASH NO.	SHAFT SIZE	GLAND OD	STUFFING BOX BORE		IB SEAL DIA	SB DEPTH	OB LENGTH	BOLT CIRCLE BY BOLT SIZE			SLOT WIDTH	O-RINGS			
												SHAFT	ROTARY	STATIONERY	LOCK RING
								A	B MAX	C MIN		C MAX	D MAX	E MIN	F MAX
							3/8"	1/2"	5/8"						
-8	1.000	4.11	2.00	2.15	1.85	1.58	2.13	3.14			0.44	120	128	129	124
-9	1.125	4.11	2.12	2.21	1.98	1.58	2.13	3.14	3.26		0.57	122	130	131	126
-10	1.250	4.36	2.25	2.33	2.10	1.58	2.13	3.33	3.46		0.57	124	132	133	128
-11	1.375	4.49	2.37	2.57	2.23	1.58	2.13	3.53	3.66		0.57	126	134	135	130
-12	1.500	4.99	2.50	2.69	2.35	1.58	2.13	3.65	3.78		0.57	128	136	137	132
-13	1.625	5.49	2.62	2.81	2.48	1.58	2.13	3.78	3.91		0.57	130	138	139	134
-14	1.750	5.49	2.75	3.07	2.60	1.58	2.13	4.03	4.16		0.57	132	140	141	136
-15	1.875	5.49	2.87	3.32	2.73	1.58	2.13	4.28	4.41	4.53	0.69	134	142	143	138
-16	2.000	5.99	3.00	3.44	2.85	1.58	2.13	4.40	4.53	4.65	0.69	136	144	145	140
-17	2.125	5.99	3.12	3.50	2.98	1.58	2.13	4.46	4.59	4.71	0.69	138	146	147	142
-18	2.250	5.99	3.25	3.69	3.10	1.58	2.13	4.65	4.78	4.90	0.69	140	148	149	144
-19	2.375	6.49	3.37	3.81	3.23	1.58	2.13	4.77	4.90	5.02	0.69	142	150	151	146
								1/2"	5/8"	3/4"					
-20	2.500	7.71	4.00	4.44	3.73	2.05	2.50	5.42	5.55		0.69	230	236	237	151
-21	2.625	7.83	4.12	4.56	3.86	2.05	2.50	5.50	5.62		0.69	231	237	238	151
-22	2.750	7.94	4.25	4.69	3.97	2.05	2.50	5.65	5.77		0.69	232	238	239	152
-23	2.875	7.99	4.37	4.81	4.10	2.05	2.50	5.80	5.92		0.69	233	239	240	152
-24	3.000	8.19	4.50	4.94	4.22	2.05	2.50	5.93	6.05		0.69	234	240	241	153
-25	3.125	8.31	4.62	5.06	4.35	2.05	2.50	6.02	6.14	6.27	0.81	235	241	242	153
-26	3.250	8.44	4.75	5.19	4.47	2.05	2.50	6.18	6.31	6.43	0.81	236	242	243	154
-27	3.375	8.49	4.87	5.31	4.60	2.05	2.50	6.31	6.44	6.56	0.81	237	243	244	154
-28	3.500	8.72	5.00	5.44	4.72	2.05	2.50	6.38	6.51	6.63	0.81	238	244	245	155
-29	3.625	8.84	5.12	5.56	4.85	2.05	2.50	6.52	6.64	6.77	0.81	239	245	246	155
-30	3.750	8.96	5.25	5.69	4.97	2.05	2.50	6.66	6.78	6.91	0.81	240	246	247	156
-31	3.875	8.99	5.37	5.81	5.10	2.05	2.50	6.76	6.90	7.03	0.81	241	247	248	156
-32	4.000	8.99	5.50	5.94	5.22	2.05	2.50	6.91	7.05	7.16	0.81	242	248	249	157
-33	4.125	9.34	5.62	6.06	5.35	2.05	2.50	7.03	7.15	7.28	0.81	243	249	250	157
-34	4.250	9.49	5.75	6.19	5.47	2.05	2.50	7.18	7.30	7.43	0.81	244	250	251	158
-35	4.375	9.49	5.87	6.31	5.60	2.05	2.50	7.28	7.40	7.53	0.81	245	251	252	158
-36	4.500	10.49	6.00	6.44	5.72	2.05	2.50	7.40	7.53	7.65	0.81	246	252	253	159
			C MIN					7/8"	1"	1 1/8"					
-38	4.75	10.99	6.75		6.38	3.25	4.09	8.92	9.04	9.17		351	359	361	253
-40	5.00	11.24	7.00		6.63	3.25	4.09	9.17	9.29	9.42		353	361	362	255
-42	5.25	11.49	7.25		6.88	3.25	4.09	9.42	9.54	9.67		355	362	363	257
-44	5.50	11.74	7.50		7.13	3.25	4.09	9.67	9.79	9.92		357	363	364	259
-46	5.75	11.99	7.75		7.38	3.25	4.09	9.92	10.04	10.17		359	364	365	260
-48	6.00	12.24	8.00		7.63	3.25	4.09	10.17	10.29	10.42		361	365	366	261
-50	6.25	12.49	8.25		7.88	3.25	4.09	10.42	10.54	10.67		362	366	367	262
-52	6.50	12.74	8.50		8.13	3.25	4.09	10.67	10.79	10.92		363	367	368	263
-54	6.75	12.99	8.75		8.38	3.25	4.09	10.92	11.04	11.17		364	368	369	264
-56	7.00	13.24	9.00		8.63	3.25	4.09	11.17	11.29	11.42		365	369	370	265
-58	7.25	13.49	9.25		8.88	3.25	4.09	11.42	11.54	11.67		366	370	371	266
-60	7.50	13.74	9.50		9.13	3.25	4.09	11.67	11.79	11.92		367	371	372	267
-62	7.75	13.99	9.75		9.38	3.25	4.09	11.92	12.04	12.17		368	372	373	268
-64	8.00	14.24	10.00		9.63	3.25	4.09	12.17	12.29	12.42		369	373	374	269

280 MIXER DIMENSIONAL DATA (METRIC)

SHAFT SIZE	GLAND OD	STUFFING BOX BORE		IB SEAL DIA	SB DEPTH	OB LENGTH	BOLT CIRCLE BY BOLT SIZE			SLOT WIDTH	O-RINGS				
											SHAFT	ROTARY	STATIONERY	LOCK RING	
							A	B MAX	C MIN		C MAX	D MAX	E MIN	F MAX	G MIN
							10 mm	12 mm	16 mm						
35	114	60	62	56	40	54	91	92		14	126	134	135	130	
38	127	63	68	59	40	54	94	95		14	128	136	137	132	
60	165	86	97	82	40	54	122	124	128	17	142	150	151	146	
							12 mm	16 mm	20 mm						
65	199	102	116	98	52	64	139	143		17	231	237	238	151	
70	202	108	119	101	52	64	143	147		17	232	238	239	152	
75	208	114	125	107	52	64	150	154		17	234	240	241	153	
80	211	117	129	110	52	64	152	156	160	21	235	241	242	153	
85	216	124	135	117	52	64	160	164	168	21	237	243	244	154	
90	225	130	141	123	52	64	165	169	173	21	239	245	246	155	
95	228	133	144	126	52	64	168	172	176	21	240	246	247	156	
100	228	140	151	132	52	64	175	179	183	21	242	248	249	156	
110	241	149	160	142	52	64	184	188	192	21	245	251	252	158	
			C MIN				20 mm	24 mm	30 mm						
120	279	171		162	83	104	226	230	236		351	359	361	253	
130	292	184		175	83	104	239	242	248		355	362	363	257	
140	298	190		181	83	104	245	249	255		357	363	364	259	
150	311	203		194	83	104	258	261	267		361	365	366	260	
160	324	216		207	83	104	270	274	280		363	367	368	262	
170	330	222		213	83	104	277	280	286		364	368	369	263	
180	343	235		226	83	104	289	293	299		366	370	371	265	
190	349	241		232	83	104	296	299	305		367	371	372	266	
200	362	254		245	83	104	308	312	318		369	373	374	268	

280 MIXER JUMBO DIMENSIONAL DATA (INCH)

DASH NO.	SHAFT SIZE	GLAND OD	STUFFING BOX BORE	IB SEAL DIA	SB DEPTH	OB LENGTH	BOLT CIRCLE BY BOLT SIZE			O-RINGS			
										SHAFT	ROTARY	STATIONERY	LOCK RING
							A	B MAX	C MIN	D MAX	E MIN	F MAX	G MIN
							7/8"	1"	1 1/8"				
-66	8.25	17.76	11.50	11.01	4.29	5.72	14.25	14.38	14.50	446	449	450	374
-68	8.50	18.01	11.75	11.26	4.29	5.72	14.50	14.63	14.75	446	449	450	374
-70	8.75	18.26	12.00	11.51	4.29	5.72	14.75	14.88	15.00	447	450	451	376
-72	9.00	18.51	12.25	11.76	4.29	5.72	15.00	15.13	15.25	447	450	451	376
-74	9.25	18.76	12.50	12.01	4.29	5.72	15.25	15.38	15.50	448	451	452	378
-76	9.50	19.01	12.75	12.26	4.29	5.72	15.50	15.63	15.75	448	451	452	378
-78	9.75	19.26	13.00	12.51	4.29	5.72	15.75	15.88	16.00	449	452	453	379
-80	10.00	19.51	13.25	12.76	4.29	5.72	16.00	16.13	16.25	449	452	453	379
-82	10.25	19.76	13.50	13.01	4.29	5.72	16.25	16.38	16.50	450	453	454	380
-84	10.50	20.01	13.75	13.26	4.29	5.72	16.50	16.63	16.75	450	453	454	380
-86	10.75	20.26	14.00	13.51	4.29	5.72	16.75	16.88	17.00	451	454	455	381
-88	11.00	20.51	14.25	13.76	4.29	5.72	17.00	17.13	17.25	451	454	455	381
-90	11.25	20.76	14.50	14.01	4.29	5.72	17.25	17.38	17.50	452	455	456	5-902
-92	11.50	21.01	14.75	14.26	4.29	5.72	17.50	17.63	17.75	452	455	456	5-902
-94	11.75	21.26	15.00	14.51	4.29	5.72	17.75	17.88	18.00	453	456	457	382
-96	12.00	21.51	15.25	14.76	4.29	5.72	18.00	18.13	18.25	453	456	457	382

280 MIXER JUMBO DIMENSIONAL DATA (METRIC)

SHAFT SIZE	GLAND OD	STUFFING BOX BORE	IB SEAL DIA	SB DEPTH	OB LENGTH	BOLT CIRCLE BY BOLT SIZE			O-RINGS				
									SHAFT	ROTARY	STATIONERY	LOCK RING	
						A	B MAX	C MIN	D MAX	E MIN	F MAX	G MIN	
							20 mm	24 mm	30 mm				
210	458	299	286	109	146	368	372	378	446	449	450	374	
220	464	305	293	109	146	374	378	384	447	450	451	376	
230	477	318	305	109	146	387	391	397	448	451	452	378	
240	483	324	312	109	146	393	397	403	448	451	452	378	
250	496	337	324	109	146	406	410	416	449	452	453	379	
260	502	343	331	109	146	412	416	422	450	453	454	380	
270	515	356	343	109	146	425	429	435	451	454	455	381	
280	528	369	356	109	146	438	442	448	452	455	456	5-902	
290	534	375	362	109	146	444	448	454	452	455	456	5-902	
300	547	388	375	109	146	457	461	467	453	456	457	382	

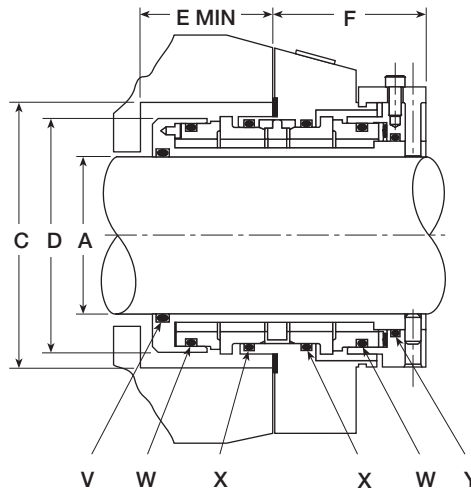
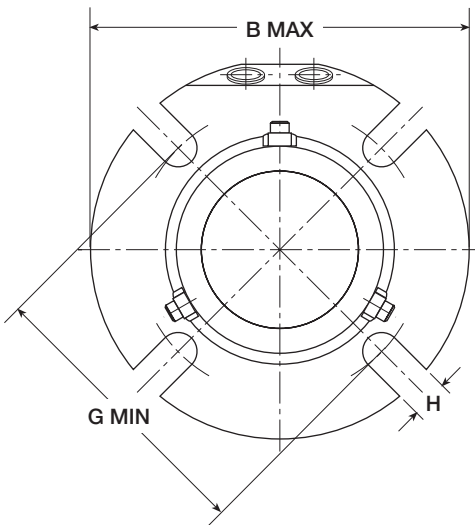

KEY

- A - Shaft Size
- B - Maximum Gland Diameter
- C - Stuffing Box Inside Diameter
- D - Seal Diameter in Stuffing Box
- E - Minimum Stuffing Box Depth
- F - Outboard Seal Length
- G - Minimum Bolt Circle by Bolt Size
- H - Slot Width
- V - Shaft O-Ring
- W - Rotary O-Ring
- X - Stationary O-Ring
- Y - Lock Ring O-Ring

280 is a trademark of A.W. Chesterton Company



860 Salem Street
Groveland, MA 01834 USA
Telephone: 781-438-7000 Fax: 978-469-6528
www.chesterton.com

© 2015 A.W. Chesterton Company.
Registered trademark owned and licensed by
A.W. Chesterton Company in USA and other countries.

ISO Certifications available at www.chesterton.com/corporate/iso